

Z-20-000-024 Series

Miniature Position Indicator



- Power down memory
- Reference function
- Multi edge counter
- Pulse scaling factor
- Selectable decimal point
- Digital Brightness control
- Up/down function
- Difference counting mode
- Sign for counting direction

1. Contents

| | | |
|------------|--|-----------|
| 1. | CONTENTS | 2 |
| 2. | INTRODUCTION | 3 |
| 3. | SET COUNTER | 3 |
| 4. | PARAMETER SETTING | 3 |
| 5. | PARAMETER LIST | 4 |
| 5.1 | Programming-example | 4 |
| 6. | CONNECTION | 5 |
| 7. | INSTALLATION HINTS | 6 |
| 8. | DIMENSIONS | 7 |
| 9. | TECHNICAL SPECIFICATIONS | 8 |
| 10. | TYPE DESIGNATION | 9 |
| 11. | LIABILITY EXCLUSION / GUARANTEE | 10 |

2. Introduction

This small, compact instrument has an 8 mm high red LED-display and provides a convenient, precise and easily readable indication of position. Using the front located keypad (and also an external signal) the display can be reset to zero or preset a datum value.

3. Set Counter

It is possible to alter the indicated value, by using the front located keys:

- **Reset Counter:** Press **F + RESET** at the same time
- **Preset Datum:** Press **F + SET** at the same time

The indicator begins to count up (adding) at three progressive speed rates:

- Rate 1 :** at 1 Hz for 10 sec.
- Rate 2 :** at 10 Hz for 10 sec.
- Rate 3 :** at 1000 Hz as long as pushbutton are depressed.

It is necessary, shortly before the desired value is reached, to release the button and reactivate, so as to approach position at the slowest rate.

A fixed datum value can be deposited in register **09**. These additional function must be released in register **16** before (see parameter list on next Page).

4. Parameter setting

Please note: To get access to the parameter settings, the switch on the rear must be closed!

The registers of the indicator will be programmed with the buttons located on front. To enter the set up-mode all button has to be pressed simultaneously for 5 seconds. The keypad has the following functions:

- F** → entry in to parameter-selection and parameter-end of programming
- RESET** → select digit to be changed
- SET** → increment a digit between 0 at 9

5. Parameter list

| No. | Function | Range |
|------------|----------------------|--|
| 01 | Counting mode | 0 = Differential 1 = back/forward |
| 03 | decimal point | 0 -3 |
| 04 | Memory | 0 no Memory 1 with Memory |
| 06 | Edge triggering | 0 = X1 1 = X2 2 = X4 |
| 07 | Sign-Symbol | 0 = +/- active 1 = +/- inactive |
| 08 | Pulse factor | 0.0001 - 9.9999 |
| 09* | Reference value | 0.0001 - 9.9999 * (see No.16) |
| 14 | Display brightness | 0 – 9 |
| 16 | Additional functions | 0 = standard 1 = SN007 2 = Parameter No. 09 enabled |

5.1 Programming-example:

Adjustment of pulse factor:

1. **Close the switch** on the rear of the unit
2. Press **F**
3. Press **RESET** → to select digit 1 for alteration
4. Press **SET** → 8 times to get parameter-number 08 in the display
5. Press **F** → to select parameter-value
6. Press **RESET** → to select the digit to be changed
7. Press **SET** → to increment the digit to be changed
8. Press **F** → to store the value to the internal Ram
and prepare indicator for change of other parameters

9. **Open the switch** on the rear of the unit

Now the new factor is stored and the Z20 back in the normal operation mode.

6. Connection

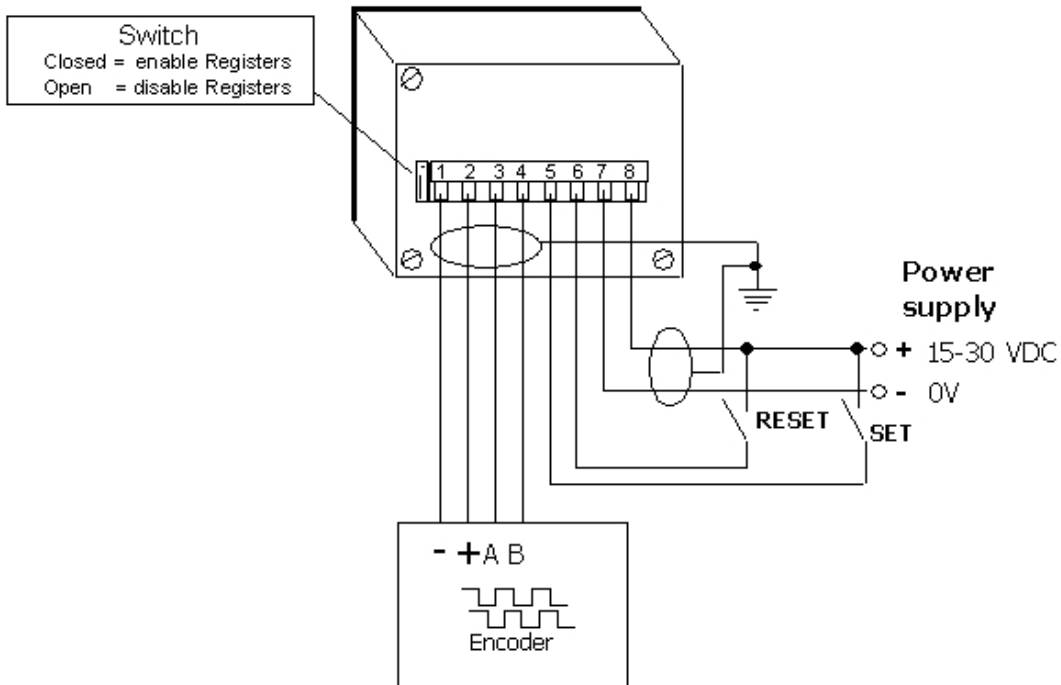

| Pin No. | Function |
|---------|------------------|
| 1 | 0 V / GND |
| 2 | 15... 30 VDC out |
| 3 | Kanal A |
| 4 | Kanal B |
| 5 | Set (PNP) |
| 6 | Reset (PNP) |
| 7 | 0 V / GND |
| 8 | 15... 30 VDC in |

7. Installation Hints



This position indicator is designed and constructed for use in arduous industrial applications and as immune to electrical interference as possible. Care should however be taken when fitting electronic equipment into machinery. To guarantee a perfect operation of the controller, the following (external) measures have to be taken additionally:

Place of installation:

Don't install the controller near to sources of interference generating strong inductive or capacitive interferences or strong electrostatic fields.

Install the external power supply directly beside the controller to avoid long low voltage wires.

Power supply:

Connect the external power supply to a phase of 230 VAC or 115 VAC, which is not used for engines. If not possible use a galvanic separation over an additional transformer.

Wire installation:

Install all wires for low voltages and encoders always separately from power wires (230 VAC/400 VAC). Avoid to install these wires close to any contactor or contactor wires.

Shielding:

All external signal wires have to be installed shielded:

1. Rotary encoder wires and Analog input wires
2. Wires for all other input signals
3. Wires for all output signals
4. Wires from the power supply to the controller

All shields have to be connected centrally low ohm to **PE** (earth potential), connect only one-sided at the Z20 indicator.

IMPORTANT!

1. Don't connect the Z20 - GND to **PE** (earth potential)
2. Don't connect the shielding on both sides to **PE** (earth potential)
3. If the protective ground potential is heavily "contaminated" by interference voltages, try to connect the shielding to the GND potential instead of **PE** (earth potential)

Fault clearance:

If there occurs interferences in spite of applying all above mentioned measures, proceed as follows:

1. Add RC elements over contactor reels of AC contactors (for example 0,1 μ F/100 Ω).
2. Add recovery diodes over DC inductances
3. Add RC elements over each engine phase (in connector box of the engine)
4. Install a power filter before the external power supply

8. Dimensions

Cut out

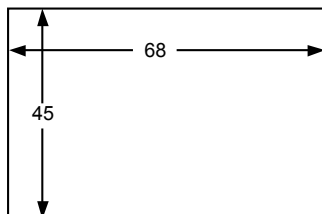

Side view

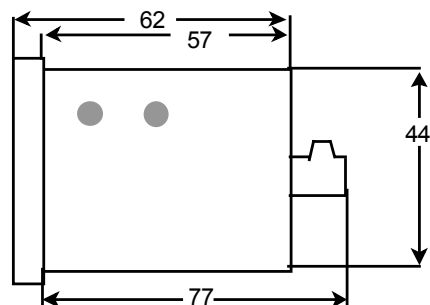

External dimensions

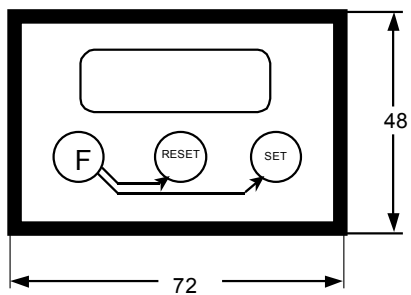

9. Technical specifications

Z20

| | |
|-----------------------------|---|
| Power Supply | 15 – 30 VDC |
| Power consumption | 1 VA |
| Counting frequency | 20 KHz = 2 m/s at 0.1 mm resolution (more on request) |
| Encoder supply output | = Power Supply |
| Display | Red 5 digits LED display + sign, 8 mm high |
| Input frequency | 90° phase shifted square waves (12 V level) |
| External set / reset inputs | Potential free inputs (max. 10 Hz) |
| Power down memory | EE-Prom |
| Housing | Black plastic panel housing |
| Install depth | 77 mm incl. Connector |
| Outer dimensions | w x h = 72 x 48 mm |
| Panel cut out | w x h = 68 x 45 mm |
| Protection class | IP 40 (installed state) |

Accessories

| | |
|-------------------------------|--|
| NG 20.0 external power supply | If no 15... 30 VDC Voltage is available, the external power supply ELGO - NG20.0 should be used. |
| Input voltage | 230 VAC/50 Hz, oder 115 V/60 Hz +/- 10% |
| Output voltage | + 16 VDC, not stabilized - max. 300 mA |
| Dimensions | DIN- Rail Snap Housing h: 80 mm, w: 45 mm, d: 60 mm with clamping screws |
| Type designation | NG 20.0 |

10. Type designation

Z20 - 000 - 024 - 0

Counter / Indicator _____

Version _____

000 = standard

001 = first special version etc.

Supply voltage _____

024 = 15... 30 VDC

Measuring system _____

0 = A/B 24V/24V 20 KHz PNP

1 = A/B/Z 24V/24V 20 KHz PNP

M = A/B - Modulation to connect MIX1-MIX3 / LMIX1...3 / EMIX1...3

N = A/B/Z - Modulation to connect MIX4 - MIX5

Accessories

External power pack 16 VDC/100mA, DIN rail mounting version _____

NG20.0

11. Liability exclusion / Guarantee

We have checked the contents of this instruction manual carefully, to the best of our knowledge and belief for conformity with the described hardware and software. Nevertheless errors, mistakes or deviations can not be excluded, therefore we do not guarantee complete conformity. Necessary corrections will be included in the subsequent editions. We appreciate your ideas and improvement suggestions very much.

Reprint, duplication and translation, even in extracts, are only allowed with a written authorization by the company ELGO Electric GmbH. We constantly strive for improving our products, therefore we keep all rights reserved for any technical modifications without any notice. ELGO Electric does not assume any liability for possible errors or mistakes.

The guarantee period is one calendar year from the date of delivery and includes the delivered unit with all components. ELGO Electric GmbH will at its option replace or repair without charge defects at the unit or the included parts, verifiable caused by faulty manufacturing and/or material in spite of proper handling and compliance to the instruction manual.

Damages verifiably not caused by ELGO Electric GmbH and due to improper handling are excluded from any guarantee e.g. by applying faulty voltage, diffusion of liquid into the interior of the engine, using force, scratching the surface, chemical influences etc.!

Subject to modifications © ELGO Electric GmbH 2005

ELGO - Electric - GmbH
Measure - Control - Position

Carl - Benz - Straße 1, D-78239 Rielasingen
phone.: 0049-7731/93 39 - 0, Fax: 2 88 03
Internet: www.elgo.de, Mail: info@elgo.de

